

Professor Hae-Gon Jeon's research team develops an AI-based algorithm for predicting the possibility of deviant behavior in an area

– Developed an algorithm to predict the occurrence of deviant behavior in a specific area using information from visual images

– To be presented at the 'AAAI Conference on Artificial Intelligence (AAAI) 2022'



▲ From left: Integrated student Junoh Lee, MS/PhD integrated student Young-Jae Park, MS/PhD integrated student Jin-Hwi Park, and Professor Hae-Gon Jeon

Understanding the impact of urban appearance and environment on society is one of the essential elements of urban planning and policies maintaining order. In recent years, major research groups in computer vision and machine learning fields such as Google, MIT, and Carnegie Mellon University are leading artificial intelligence research that supports the public good from a social structural point of view.

GIST (Gwangju Institute of Science and Technology, President Kiseon Kim) Professor Hae-Gon Jeon's research team at the AI Graduate School proposed a model for detecting the possibility of deviant behavior through the use of city visual image information based on artificial intelligence techniques.

Whereas existing methodologies infer subjective perceived safety levels such as scenery, vitality, and wealth that are not related to actual crime in the area, this research created an algorithm to predict not only crime but also non-normative deviant behavior such as trespassing.

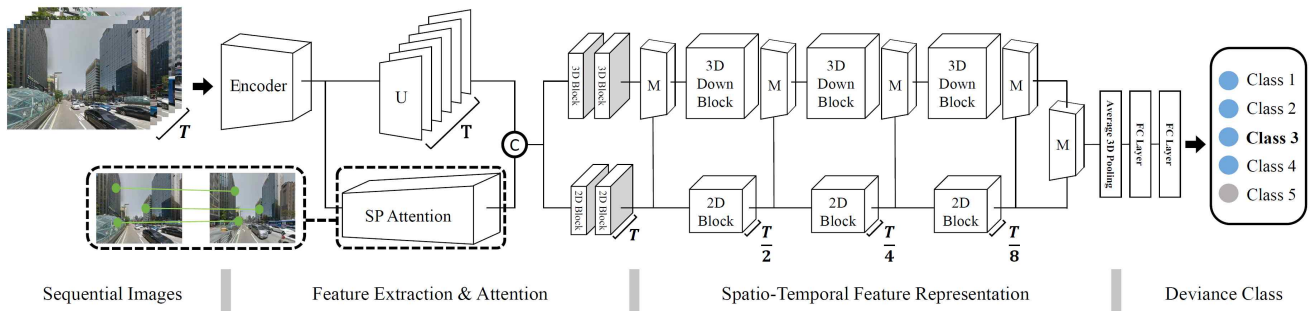

▲ The network structure for predicting the occurrence of deviant behavior proposed in this study. A structure that models the visual characteristics of a specific area and predicts the possibility of deviating behavior from the input image location through an artificial neural network.

Whereas previous studies predict risk based on a single image of a narrow place, this is the world's first large-scale objective crime/complaint report-based research. The occurrence of deviant behavior was detected and predicted by constructing a visual recognition dataset and precisely searching for a comprehensive range of places.

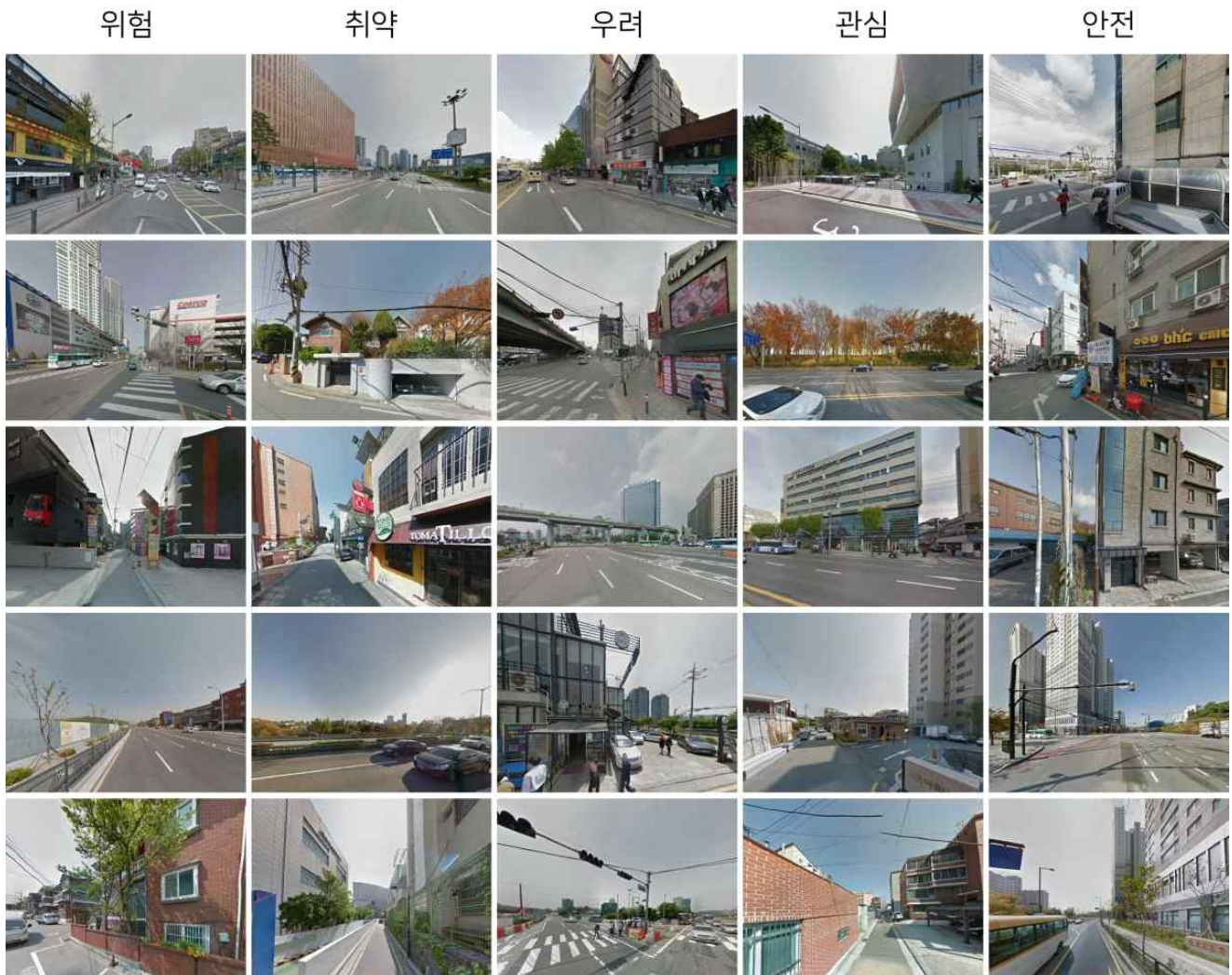

▲ An example of Seoul images among the data for this research: The more you go to the left, the higher the possibility of inducing deviant behavior.

In particular, this study is expected to take a step forward by substantially contributing to the establishment of crime prevention and policing policies, unlike existing crime and investigation-related research that simply use demographic information such as the number of people by age, middle class ratio,

and suicide rate and the relationship between crime and crime. This is expected to bring a step forward in the establishment of existing security policies through risk prediction.

Professor Hae-Gon Jeon said, "The greatest significance of this research is that it implemented a more comprehensive deviance theory as an artificial intelligence model rather than the mainstream urban security theory based on the existing broken window theory. It is expected that artificial intelligence technology will be more actively applied to social science fields such as sociology and criminal psychology, which study the relationship between visual information and human criminal behavior and deviant behavior."

This research was led by GIST AI Graduate School Professor Hae-Gon Jeon of (corresponding author) and conducted by AI Graduate School MS/PhD integrated students Jin-Hwi Park (first author) and Young-Jae Park (first author) with support from the police. The Smart Police Intelligence Center of the Police Science Institute at the Korean National Police University processed police crime data and supported the research team with analysis. The research will be presented on February 22, 2022, at the AAAI Conference on Artificial Intelligence, the world's top conference in the field of artificial intelligence.